

GIRLING K 292

SERVICE KIT INSTRUCTIONS

NECESSAIRE DE REPARATION
GIRLING
MODE D'EMPLOI

GIRLING REPARATURSATZ
GEBRAUCHSANWEISUNGEN

SERIE DI RICAMBI (KIT)
GIRLING
ISTRUZIONI PER L'IMPIEGO

Girling Ltd., Birmingham Road West Bromwich, Staffs B71 4JR England.

HYDRAULIC SERVO UNIT MK 2A

Dismantling

Before proceeding, obtain a 15in. (38 cm) length of 1/8in. (3mm) welding wire and a good pair of circlip pliers.

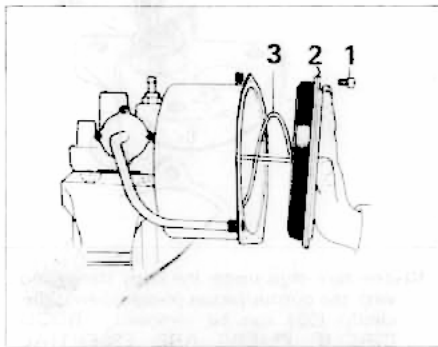

1. Clamp unit in bench vice as shown. Unscrew end cover bolts (1), supporting the end cover (2) against spring pressure (3) as last bolts are removed.

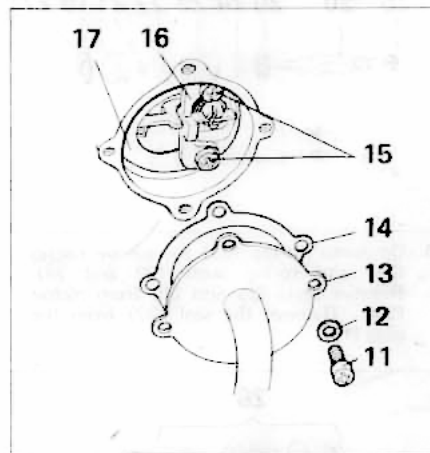

3. Remove set screws (11), washers (12), cover (13) and gasket (14). Remove set screws (15), lever guide (16) and spring plate (17).

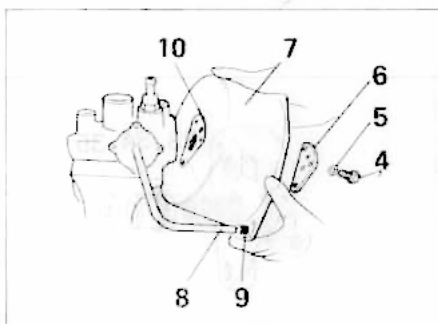

2. Remove bolts (4), washers (5) and plate (6). Carefully pull vacuum cylinder (7), to separate pipe (8) from its grommet (9). Remove gasket (10).

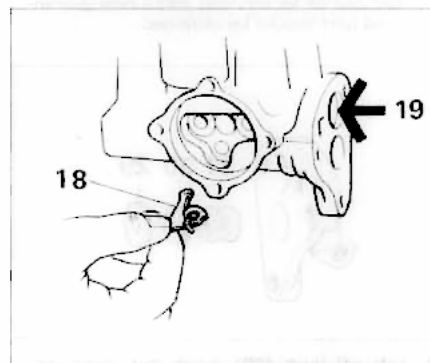

4. To release 'T' lever valve (18), push in plug (19) and lift out lever.

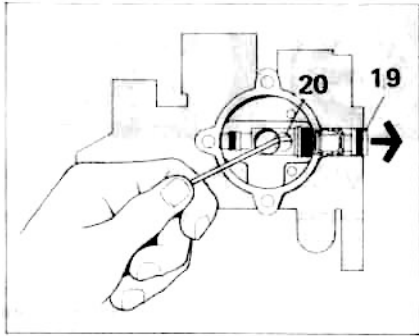

5. Insert bent 1/8 in. (3mm) welding wire into hole in control piston (20). Lever piston to push out plug (19) and lift out piston.

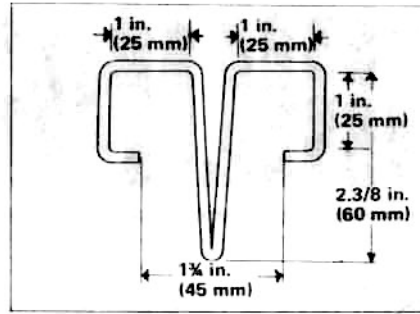

9. Using a 12 in. (30 cm) length of 1/8 in. (3mm) welding wire, make up special tool to dimensions shown.

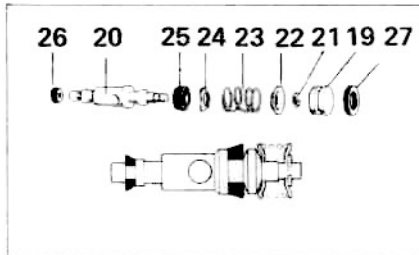

6. Compress spring (23) to remove circlip (21) and spring seats (22 and 24). Remove seals (25 and 26) from piston (20). Remove the seal (27) from the plug (19).

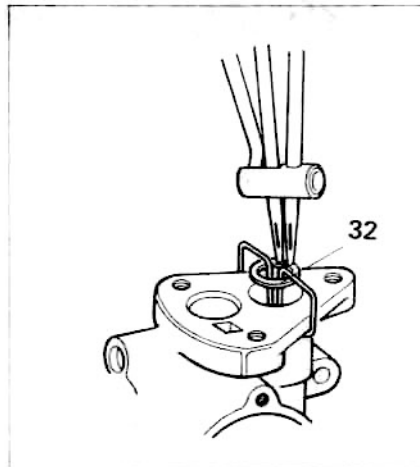

10. The tool clips under the body flange and with the output piston pushed down, the circlip (32) can be removed. **GOOD CIRCLIP PLIERS ARE ESSENTIAL FOR A SCORED BORE COULD RESULT IN A BRAKE FAILURE AND THE CIRCLIP MUST NOT SLIP WHEN BEING REMOVED.**

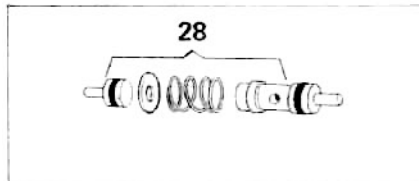

7. If the control piston is in two parts and looks like this (28) the unit is considered too old to be serviced and a new guaranteed unit should be obtained.

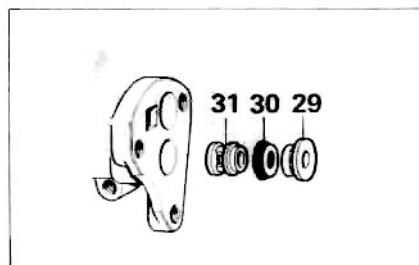

8. Lift off bush (29), hook out gland seal (30) and shake out spacer (31).

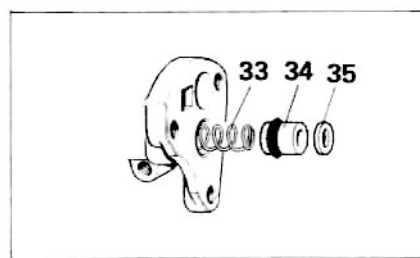

11. Removal of the tool will release the spring (33), piston (34) and washer (35).

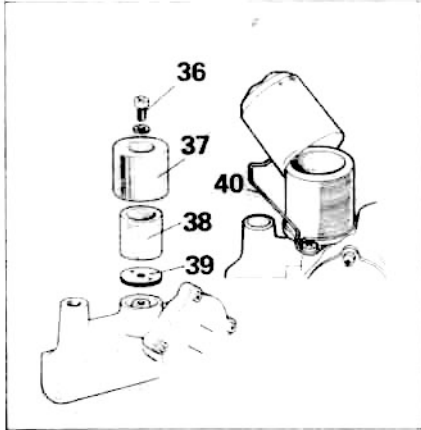

12 Unscrew the setscrew (36) to remove the air filter (38), cover (37) and base washer (39). Filter covers on early units were retained by a clip (40).

Cleaning

Scrupulous cleanliness is now essential. Wash hands before proceeding and lay out a clean sheet of paper on which to place the parts. The new parts in the Girling Service Kit will indicate which used parts should be discarded.

Clean the remaining parts thoroughly with Girling Cleaning Fluid or unused Castrol-Girling Brake Fluid and place them on the clean sheet of paper and allow to dry. Examine each part to see it is undamaged and in good working order. Special attention should be given to the pistons and piston bores in the hydraulic body, there should be no signs of corrosion, pitting, scoring or ridges. If any of these faults are evident, or if doubt exists, fit a new guaranteed unit.

Reassembly

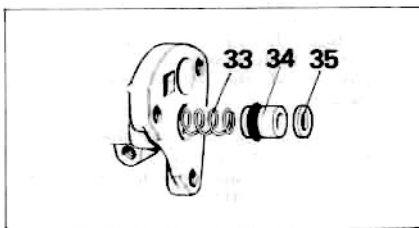

13 Fit a new seal to new output piston (34) as shown. Lubricate bore and seal with unused Castrol-Girling Brake Fluid and insert spring (33) into bore. Place washer (35) on piston

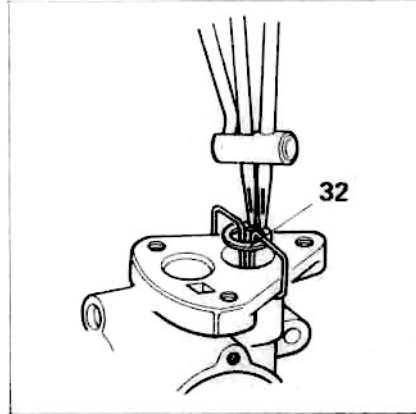

14. With wire tool, ease piston and seal into bore and clip tool under flange. REMEMBER THE CIRCLIP MUST NOT SLIP AND DAMAGE THE BORE, SO CAREFULLY FIT THE CIRCLIP INTO ITS GROOVE AND REMOVE THE WIRE TOOL.

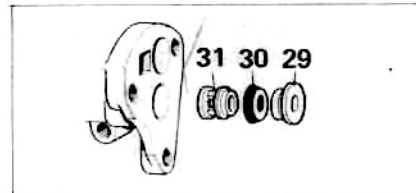

15. Fit spacer (31), gland seal (30) and spacer (29) into the bore as shown.

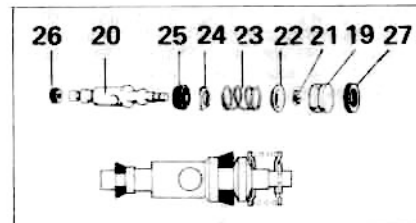

16. Fit new seals (26 and 25) to the control piston (20) as shown. Follow with the spring and spring seats, securing with the circlip. Lubricate the bore and seals with unused Castrol-Girling Brake Fluid.

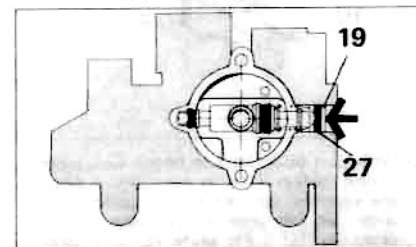

17. Aligning the hole in the control piston with that in the valve chest, insert the piston into the bore. Fit the seal (19) to the plug (27) and press into the bore.

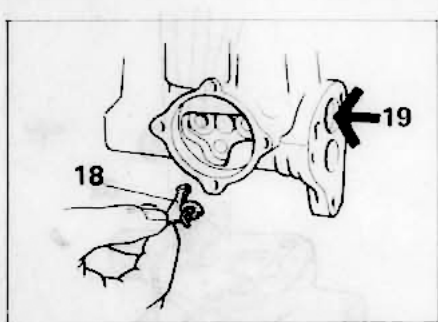

18. Insert 'T' lever valve (18) and press in plug (19) to allow round end of lever to fit easily into the hole in control piston.

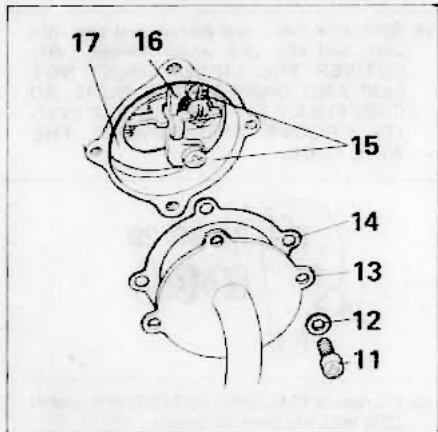

19. Fit spring plate (17) and lever guide (16). Secure with screws (15). Position new gasket (14) and cover (13) over the valve chest and secure with screws (11) and washers (12).

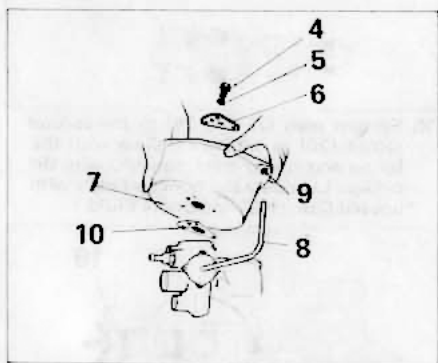

20. With unit body held in bench vice, place a new gasket (10) in position. Locate the vacuum cylinder (7) on gasket (10) with vacuum pipe (8) in new rubber grommet (9). Fit plate (6) and using bolts (4) with new copper washers (5). **TIGHTEN BOLTS FINGER TIGHT ONLY.**

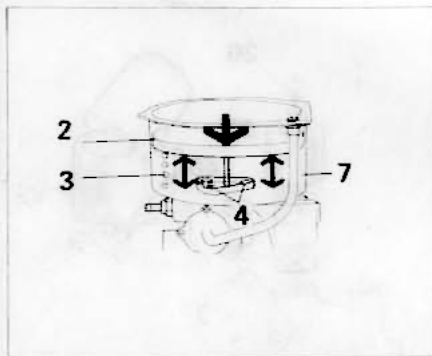

21. Before tightening the bolts, place the piston return spring (3) and piston (2) in position and push it down through the full stroke several times to align the bearing bush. Taking care not to move the vacuum cylinder (7) remove the piston and spring and tighten the bolts (4).

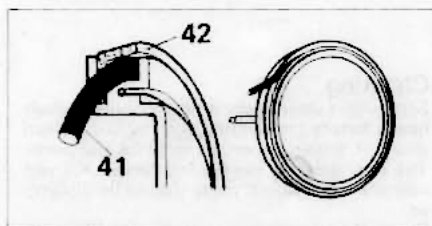

22. Fit new rubber strip (41) under leather outer seal (42) and coat the seal with special servo grease from kit. Keep the grease away from hydraulic parts.

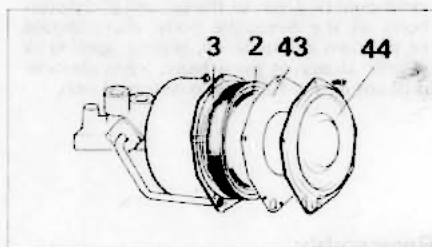

23. Refit the spring (3) and piston (2). Fit a new gasket (43) to the cover plate (44) and place the cover plate on top on the piston. Press down, fit the nuts and bolts round the flange and tighten securely.

If the unit is not fitted to the vehicle immediately, the open ports should be covered with suitable tape to prevent the entry of foreign matter.